

PCFY-P-VKM-E

1. SPECIFICATIONS..... 1 - 96

2. EXTERNAL DIMENSIONS 1 - 97

3. CENTER OF GRAVITY 1 - 100

4. ELECTRICAL WIRING DIAGRAMS 1 - 101

5. SOUND LEVELS 1 - 102

 5-1. Sound levels 1 - 102

 5-2. NC curves 1 - 102

6. OA INTAKE-STATIC PRESSURE CURVES..... 1 - 103

7. TEMPERATURE/AIRFLOW DISTRIBUTIONS 1 - 104

 7-1. Temperature distributions 1 - 104

 7-2. Airflow distributions 1 - 105

8. OPTIONAL PARTS..... 1 - 106

 8-1. Optional parts line up for the Indoor unit..... 1 - 106

 8-2. High efficiency filter..... 1 - 106

 8-3. Drain pump 1 - 106

 8-4. Wireless remote controller kit 1 - 106

1. SPECIFICATIONS

DATA G6

Model		PCFY-P40VKM-E	PCFY-P63VKM-E	PCFY-P100VKM-E	PCFY-P125VKM-E	
Power source		1-phase 220-240V 50Hz, 1-phase 220V 60Hz	1-phase 220-240V 50Hz, 1-phase 220V 60Hz	1-phase 220-240V 50Hz, 1-phase 220V 60Hz	1-phase 220-240V 50Hz, 1-phase 220V 60Hz	
Cooling capacity (Nominal)	*1 kW	4.5	7.1	11.2	14.0	
	*1 kcal / h	3,900	6,100	9,600	12,000	
	*1 BTU / h	15,400	24,200	38,200	47,800	
	*2 kcal / h	4,000	6,300	10,000	12,500	
	(220V) Power input kW	0.04	0.05	0.09	0.11	
(220V) Current input	A	0.28	0.33	0.65	0.76	
Heating capacity (Nominal)	*3 kW	5.0	8.0	12.5	16.0	
	*3 kcal / h	4,300	6,900	10,800	13,800	
	*3 BTU / h	17,100	27,300	42,700	54,600	
	(220V) Power input kW	0.04	0.05	0.09	0.11	
	(220V) Current input	A	0.28	0.33	0.65	0.76
External finish		MUNSELL (6.4Y 8.9/0.4)	MUNSELL (6.4Y 8.9/0.4)	MUNSELL (6.4Y 8.9/0.4)	MUNSELL (6.4Y 8.9/0.4)	
External dimension HxWxD		mm 230x960x680	mm 230x1280x680	mm 230x1600x680	mm 230x1600x680	
		in. 9-1/16 x 37-13/16 x 26-3/4	in. 9-1/16 x 50-3/8 x 26-3/4	in. 9-1/16 x 63 x 26-3/4	in. 9-1/16 x 63 x 26-3/4	
Net weight		kg(lbs) 24(53)	kg(lbs) 32(71)	kg(lbs) 36(79)	kg(lbs) 38(84)	
Heat exchanger		Cross fin (Aluminum fin and copper tube)	Cross fin (Aluminum fin and copper tube)	Cross fin (Aluminum fin and copper tube)	Cross fin (Aluminum fin and copper tube)	
FAN	Type x Quantity		Sirocco fan x 2	Sirocco fan x 3	Sirocco fan x 4	Sirocco fan x 4
	External static press.	Pa	0	0	0	0
		mmH ₂ O	0	0	0	0
	Motor Type		DC motor	DC motor	DC motor	DC motor
	Motor output		kW 0.090	kW 0.095	kW 0.160	kW 0.160
	Driving mechanism		Direct-drive	Direct-drive	Direct-drive	Direct-drive
	Air flow rate (Low-Mid2-Mid1-High)	m ³ / min	10-11-12-13	14-15-16-18	21-24-26-28	21-24-27-31
		L/s	167-183-200-217	233-250-267-300	350-400-433-467	350-400-450-517
cfm		353-388-424-459	494-530-565-636	742-847-918-989	742-847-953-1095	
Sound pressure level (measured in anechoic room)		dB <A> 29-32-34-36	dB <A> 31-33-35-37	dB <A> 36-38-41-43	dB <A> 36-39-42-44	
Insulation material		Polyeter sheet	Polyeter sheet	Polyeter sheet	Polyeter sheet	
Air filter		PP honeycomb (long life)	PP honeycomb (long life)	PP honeycomb (long life)	PP honeycomb (long life)	
Protection device		Fuse	Fuse	Fuse	Fuse	
Refrigerant control device		LEV	LEV	LEV	LEV	
Connectable outdoor unit		R410A, R407C, R22 CITY MULTI	R410A, R407C, R22 CITY MULTI	R410A, R407C, R22 CITY MULTI	R410A, R407C, R22 CITY MULTI	
Diameter of refrigerant pipe	Liquid (R410A) (R22, R407C)	mm(in.)	6.35(1/4) Flare	9.52(3/8) Flare	9.52(3/8) Flare	9.52(3/8) Flare
		mm(in.)	6.35(1/4) Flare	9.52(3/8) Flare	9.52(3/8) Flare	9.52(3/8) Flare
	Gas (R410A) (R22, R407C)	mm(in.)	12.70(1/2) Flare	15.88(5/8) Flare	15.88(5/8) Flare	15.88(5/8) Flare
		mm(in.)	12.70(1/2) Flare	15.88(5/8) Flare	19.05(3/4) Flare	19.05(3/4) Flare
Field drain pipe size		mm(in.) O.D. 26mm(1)	mm(in.) O.D. 26mm(1)	mm(in.) O.D. 26mm(1)	mm(in.) O.D. 26mm(1)	
Drawing	External		-	-	-	-
	Wiring		-	-	-	-
	Refrigerant cycle		-	-	-	-
Standard attachment	Document		Installation Manual, Instruction Book	Installation Manual, Instruction Book	Installation Manual, Instruction Book	Installation Manual, Instruction Book
	Accessory		-	-	-	-
Optional parts	Circular duct flange		-	-	-	-
	Drain pump kit		PAC-SH83DM-E	PAC-SH84DM-E	PAC-SH84DM-E	PAC-SH84DM-E
	Square duct flange		-	-	-	-
	Filter box for rear suction		-	-	-	-
	Filter box for bottom suction		-	-	-	-
	Canvas duct for bottom suction		-	-	-	-
	Medium efficiency filter 65%		-	-	-	-
	High efficiency filter		PAC-SH88KF-E	PAC-SH89KF-E	PAC-SH90KF-E	PAC-SH90KF-E
	Maintenance panel with air intake		-	-	-	-
Wireless remote controller kit		PAR-SL94B-E	PAR-SL94B-E	PAR-SL94B-E	PAR-SL94B-E	
Remarks		* Details on foundation work, duct work, insulation work, electrical wiring, power source switch, and other items shall be referred to the Installation Manual.	* Details on foundation work, duct work, insulation work, electrical wiring, power source switch, and other items shall be referred to the Installation Manual.	* Details on foundation work, duct work, insulation work, electrical wiring, power source switch, and other items shall be referred to the Installation Manual.	* Details on foundation work, duct work, insulation work, electrical wiring, power source switch, and other items shall be referred to the Installation Manual.	

Notes :	*1 Nominal cooling conditions (subject to JIS B8615-1)	*2 Nominal cooling conditions	*3 Nominal heating conditions (subject to JIS B8615-1)	Unit converter
Indoor :	27degC D.B. / 19degC W.B. (81degF D.B. / 66degF W.B.)	27degC D.B. / 19.5degC W.B. (81degF D.B. / 67degF W.B.)	20degC D.B. (68degF D.B.)	kcal/h = kW x 860
Outdoor :	35degC D.B. (95degF D.B.)	35degC D.B. (95degF D.B.)	7degC D.B. / 6degC W.B. (45degF D.B. / 43degF W.B.)	BTU/h = kW x 3,412
Pipe length :	7.5 m (24-9/16 ft.)	5 m (16-3/8 ft.)	7.5 m (24-9/16 ft.)	cfm = m ³ /min x 35.31
Level difference :	0 m (0 ft.)	0 m (0 ft.)	0 m (0 ft.)	lbs = kg / 0.4536
				*The specification data is subject to rounding variation.

Ref.: Spec_PCFY-P40-125VKM-E

PCFY-P40VKM-E

Unit : mm

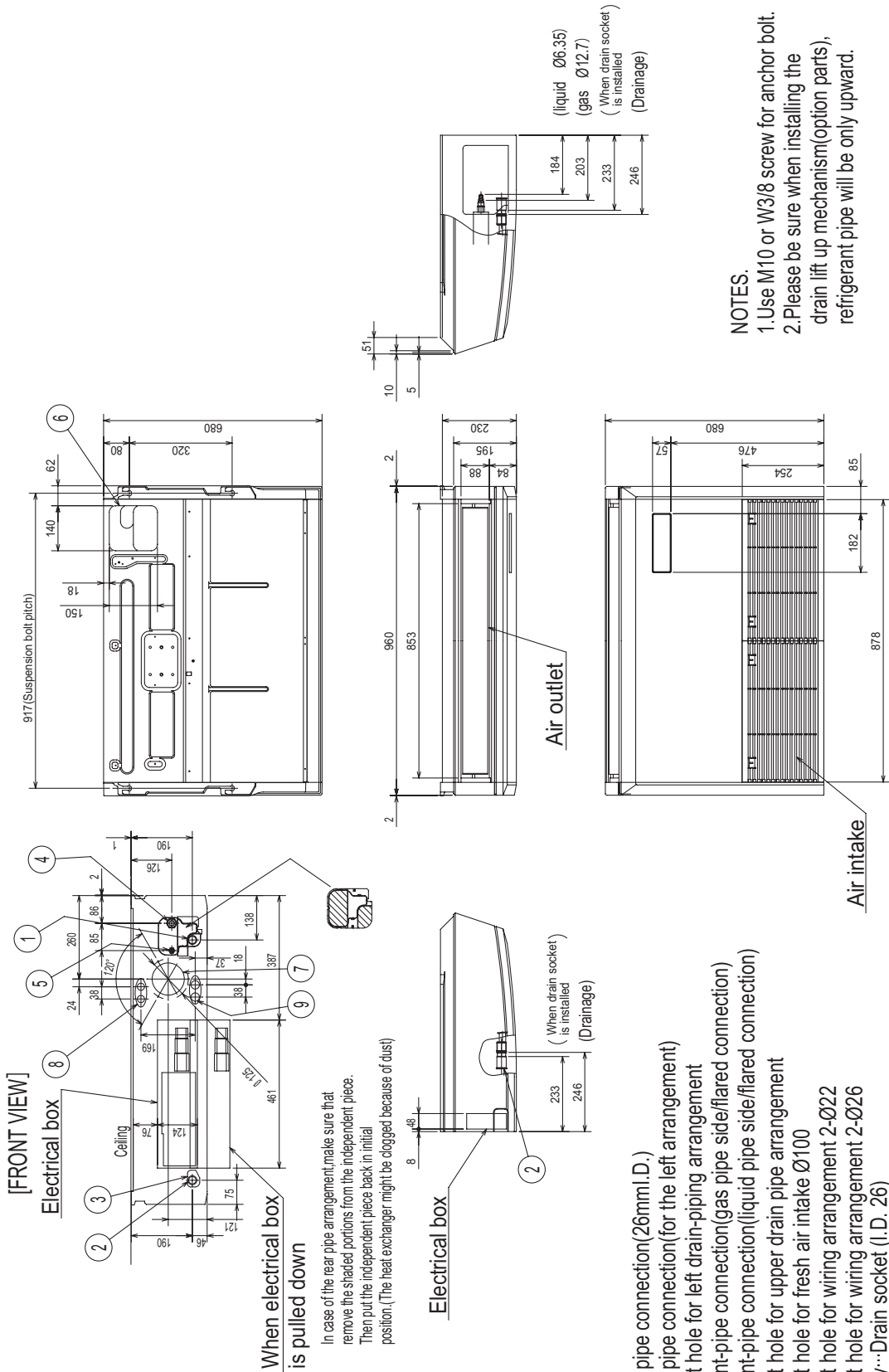

NOTES.
 1. Use M10 or W3/8 screw for anchor bolt.
 2. Please be sure when installing the drain lift up mechanism(option parts), refrigerant pipe will be only upward.

- ① Drainage pipe connection(26mm.I.D.)
 - ② Drainage pipe connection(for the left arrangement)
 - ③ Knock out hole for left drain-piping arrangement
 - ④ Refrigerant-pipe connection(gas pipe side/flared connection)
 - ⑤ Refrigerant-pipe connection(liquid pipe side/flared connection)
 - ⑥ Knock out hole for upper drain pipe arrangement
 - ⑦ Knock out hole for fresh air intake Ø100
 - ⑧ Knock out hole for wiring arrangement 2-Ø22
 - ⑨ Knock out hole for wiring arrangement 2-Ø26
- Accessory...Drain socket (I.D. 26)

PCFY-P63VKM-E

Unit : mm

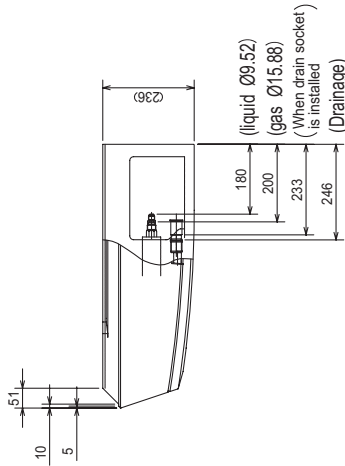
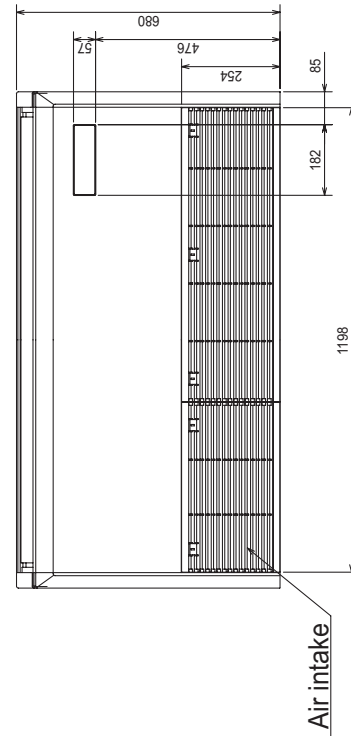
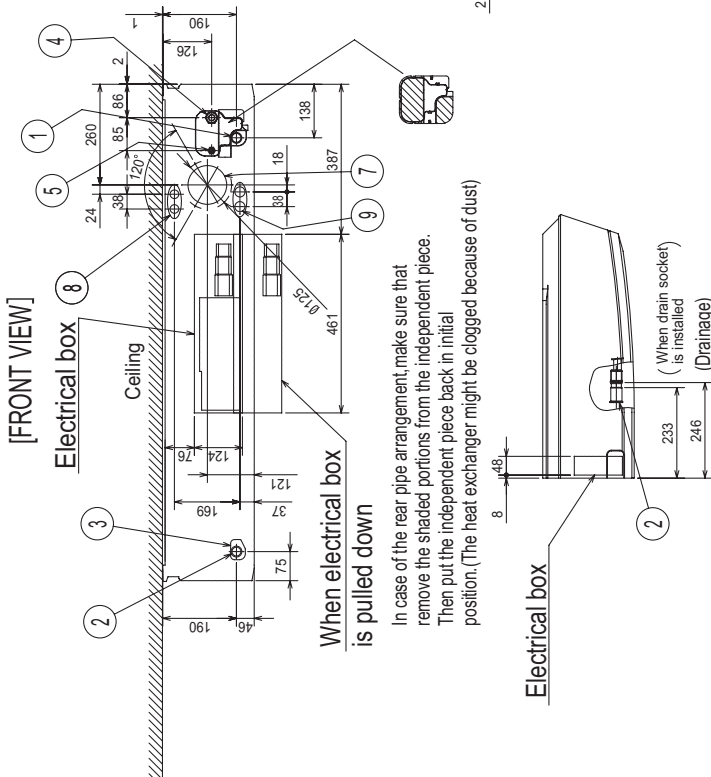

NOTES.

1. Use M10 or W3/8 screw for anchor bolt.
2. Please be sure when installing the drain lift up mechanism(option parts), refrigerant pipe will be only upward.

- ① Drainage pipe connection(26mm I.D.)
 - ② Drainage pipe connection(for the left arrangement)
 - ③ Knock out hole for left drain-piping arrangement
 - ④ Refrigerant-pipe connection(gas pipe side/flared connection)
 - ⑤ Refrigerant-pipe connection(liquid pipe side/flared connection)
 - ⑥ Knock out hole for upper drain pipe arrangement
 - ⑦ Knock out hole for fresh air intake Ø100
 - ⑧ Knock out hole for wiring arrangement 2-Ø22
 - ⑨ Knock out hole for wiring arrangement 2-Ø26
- Accessory...Drain socket (I.D. 26)

PCFY-P100,125VKM-E

Unit : mm

- ⑥ Knock out hole for upper drain pipe arrangement
- ⑦ Knock out hole for fresh air intake Ø100
- ⑧ Knock out hole for wiring arrangement 2-Ø22
- ⑨ Accessory---Drain socket (I.D. 26)

- ① Drainage pipe connection(26mm.I.D.)
- ② Drainage pipe connection(for the left arrangement)
- ③ Knock out hole for left drain-piping arrangement
- ④ Refrigerant-pipe connection(gas pipe side/flared connection)
- ⑤ Refrigerant-pipe connection(liquid pipe side/flared connection)

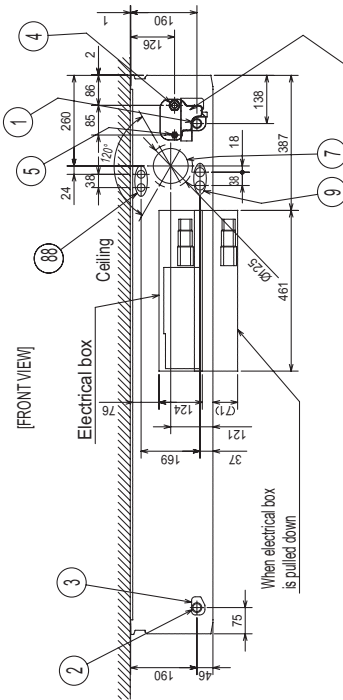

In case of the rear pipe arrangement, make sure that remove the shaded portions from the independent piece. Then put the independent piece back in initial position. (The heat exchanger might be clogged because of dust)

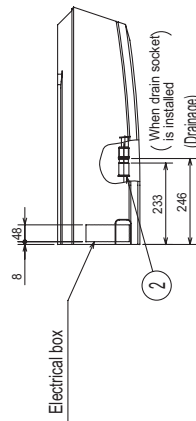

Use the current nuts meeting the pipe size of the outdoor unit.

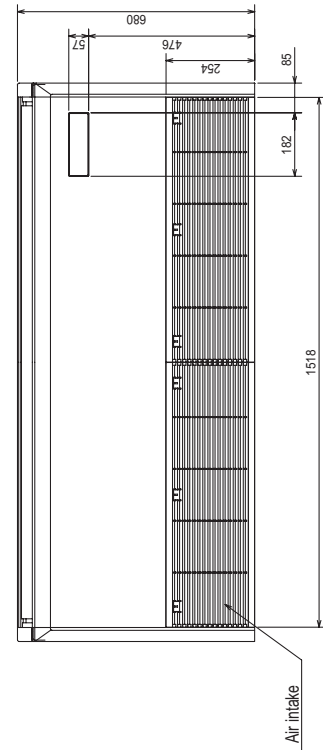
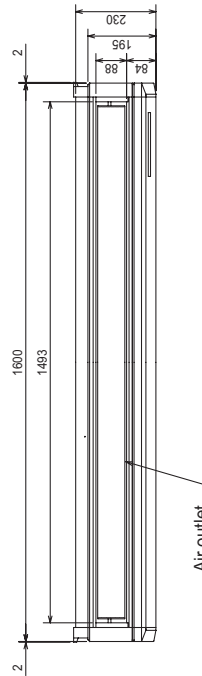
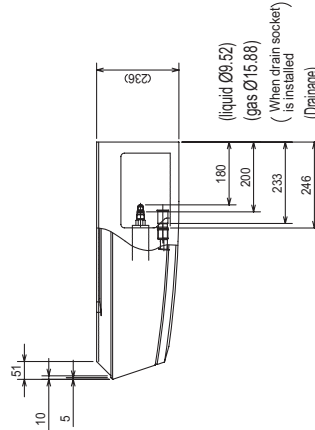
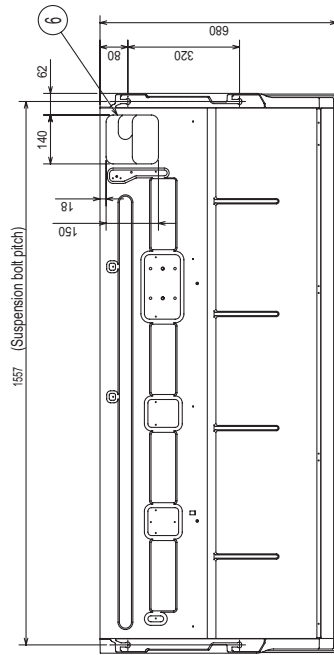

- NOTES.**
1. Use M10 or W3/8 screw for anchor bolt.
 2. Please be sure when installing the drain lift up mechanism (option parts), refrigerant pipe will be only upward.

PCFY-P40,63,100,125VKM-E

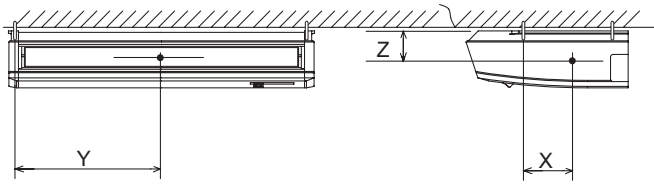

Model name	X	Y	Z
PCFY-P40VKM-E	110	450	115
PCFY-P63VKM-E	110	610	115
PCFY-P100VKM-E	110	770	115
PCFY-P125VKM-E	110	770	115

PCFY-P40, 63, 100, 125VKM-E

SYMBOL	NAME	SYMBOL	NAME
I.B	INDOOR CONTROLLER BOARD	TH22	THERMISTOR PIPE TEMP. DETECTION / LIQUID (0°C / 15kΩ, 25°C / 5.4kΩ)
CN27	CONNECTOR DAMPER	TH23	PIPE TEMP. DETECTION / GAS (0°C / 15kΩ, 25°C / 5.4kΩ)
CN32	REMOTE SWITCH	A.B	ADDRESS BOARD
CN51	CENTRALLY CONTROL	SWA	SWITCH CEILING HEIGHT SELECTOR
CN52	REMOTE INDICATION	SWC	OPTION SELECTOR
DSA	SURGE ABSORBER	SW1	MODE SELECTION
FUSE	FUSE (T6.3AL250V)	SW11	ADDRESS SETTING 1s DIGIT
SW2	SWITCH CAPACITY CODE	SW12	ADDRESS SETTING 10ths DIGIT
SW3	SWITCH MODE SELECTION	SW14	BRANCH No.
SW4	SWITCH MODEL SELECTION	OPTIONAL PARTS	
SWE	DRAIN LIFT UP MECHANISM (TEST MODE)	W/B	PCB FOR WIRELESS REMOTE CONTROLLER
X1	AUX. RELAY DRAIN LIFT UP MECHANISM (OPTIONAL PARTS)	BZ	BUZZER
ZNR01,02	VARISTOR	LED1	LED (OPERATION INDICATION : GREEN)
LEV	LINEAR EXPANSION VALVE	LED2	LED (PREPARATION FOR HEATING : ORANGE)
DCL	REACTOR	RU	RECEIVING UNIT
MF	FAN MOTOR	SW1	EMERGENCY OPERATION (HEAT / DOWN)
MV	VANE MOTOR	SW2	EMERGENCY OPERATION (COOL / UP)
TB2	TERMINAL BLOCK POWER SUPPLY	DP	DRAIN LIFT UP MECHANISM
TB5	TERMINAL BLOCK TRANSMISSION	FS	DRAIN FLOAT SWITCH
TB15	TERMINAL BLOCK MA-REMOTE CONTROLLER		
TH21	THERMISTOR ROOM TEMP. DETECTION (0°C / 15kΩ, 25°C / 5.4kΩ)		

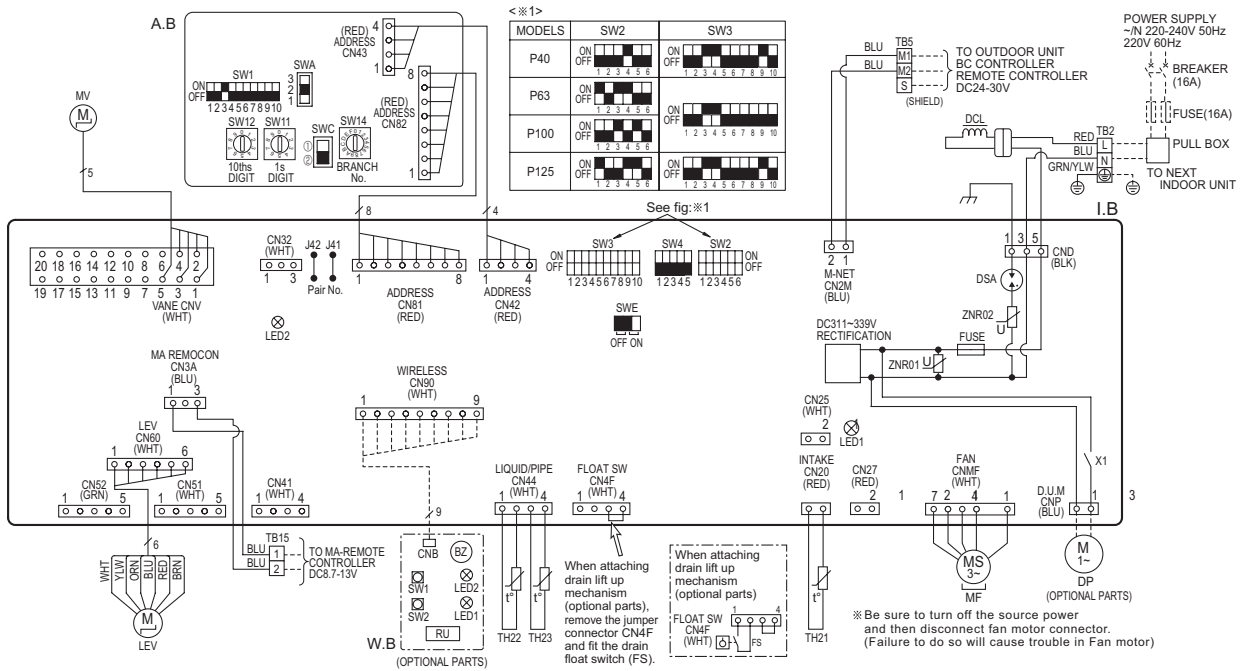

LED on indoor board for service

Mark	Meaning	Function
LED1	Main power supply	Main power supply (Indoor unit:220-240V) Power on → lamp is lit
LED2	Power supply for MA-Remote controller	Power supply for MA-Remote controller on → lamp is lit

NOTES:

- At servicing for outdoor unit, always follow the wiring diagram of outdoor unit.
- In case of using MA-Remote controller, please connect to TB15. (Remote controller wire is non-polar.)
- In case of using M-NET, please connect to TB5. (Transmission line is non-polar.)
- Symbol [S] of TB5 is the shield wire connection.
- Symbols used in wiring diagram above are, : terminal block, : connector.
- The setting of the SW2 dip switches differs in the capacity. for the detail, refer to the fig: *1.

5-1. Sound levels

Ceiling suspended

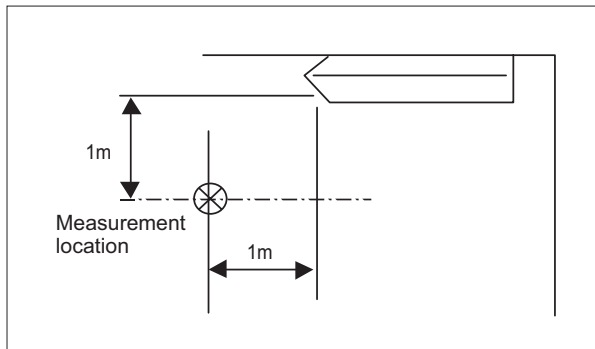

Sound level at anechoic room : Low-Middle2-Middle1-High

Model	Sound level dB (A)
PCFY-P40VKM-E	29-32-34-36
PCFY-P63VKM-E	31-33-35-37
PCFY-P100VKM-E	36-38-41-43
PCFY-P125VKM-E	36-39-42-44

* Measured in anechoic room.

5-2. NC curves

PCFY-P40VKM

External Static Pressure: 30Pa
Power Source: 200V, 50/60Hz

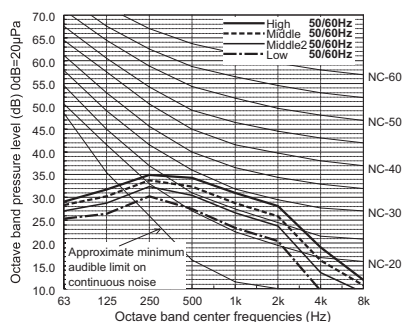

PCFY-P63VKM

External Static Pressure: 30Pa
Power Source: 200V 50/60Hz

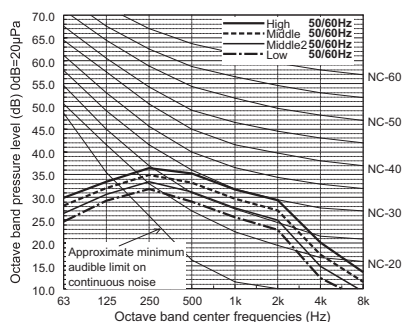

PCFY-P100VKM

External Static Pressure: 30Pa
Power Source: 200V 50/60Hz

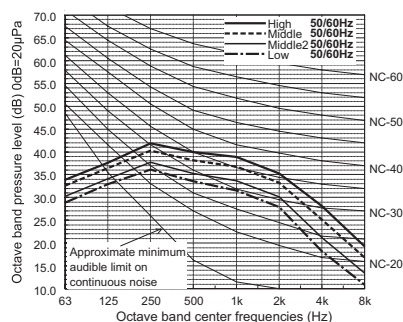

PCFY-P125VKM

External Static Pressure: 30Pa
Power Source: 200V 50/60Hz

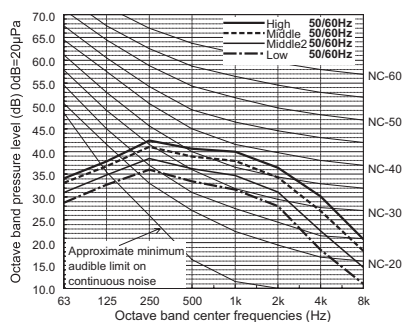

PCFY

■ PCFY-P40VKM-E

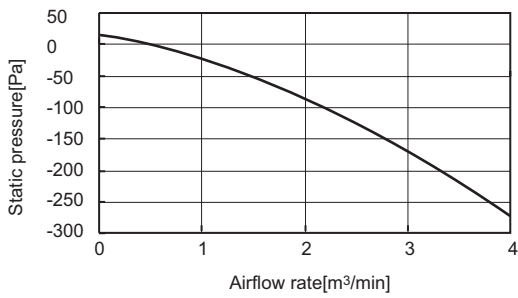

■ PCFY-P63VKM-E

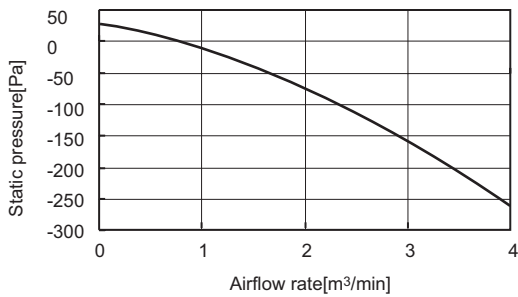

■ PCFY-P100, 125VKM-E

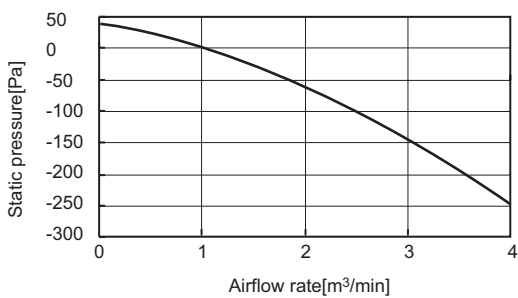

7-1. Temperature distributions

Temperature distributions

PCFY-P63VKM-E

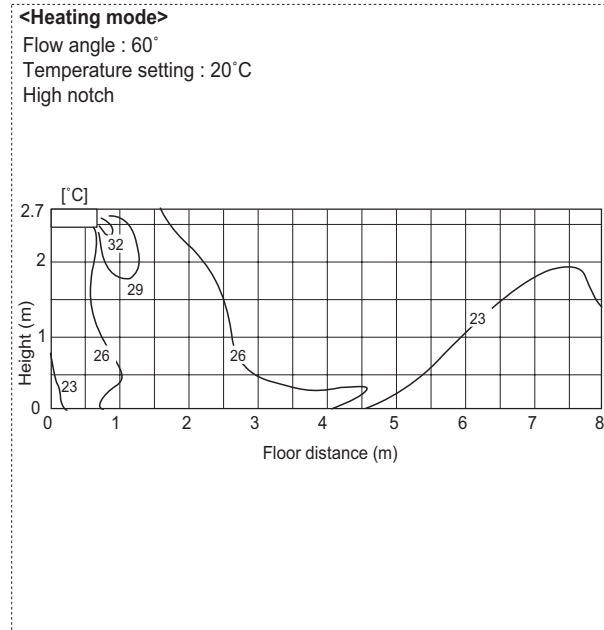
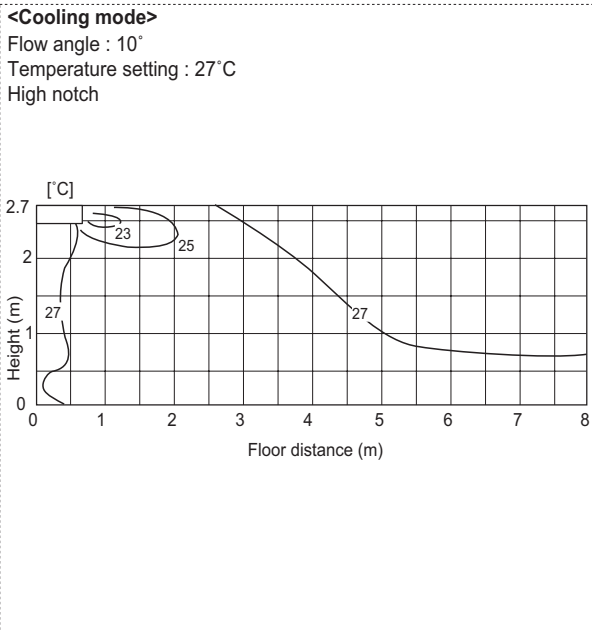

PCFY-P125VKM-E

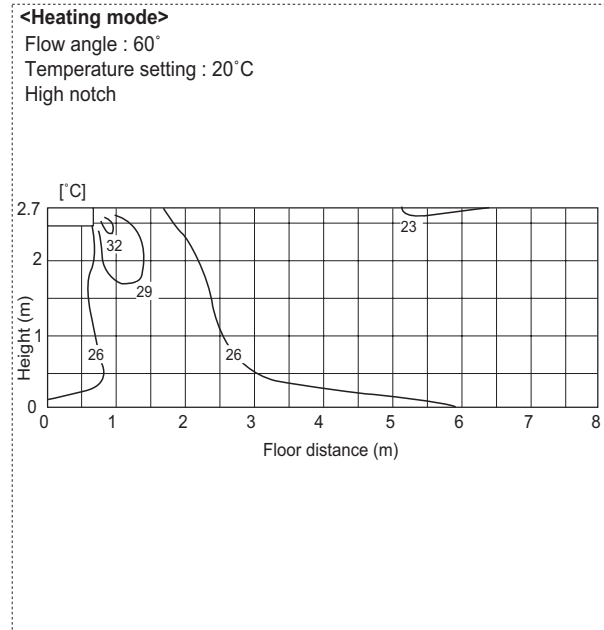
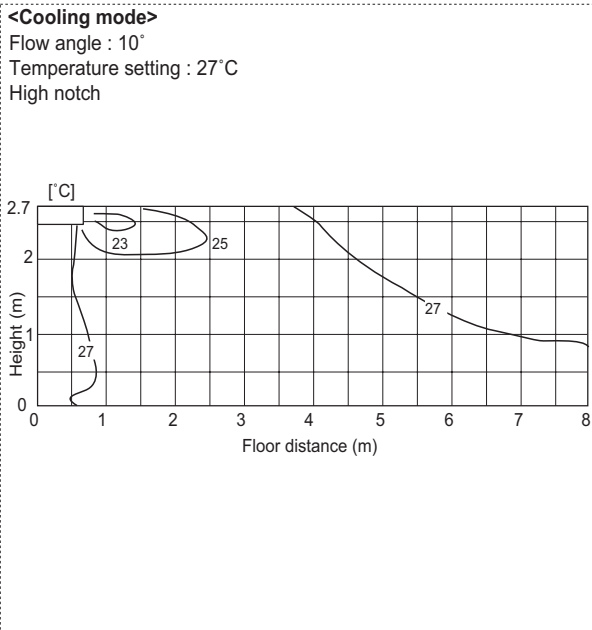

Note : These figures show typical airflow distributions in the conditions above. In the actual installation, they may differ from these figures under the influence of air temperature conditions, ceiling height, cooling/heating load, obstacles, etc.

PCFY

7-2. Airflow distributions

**Airflow distributions
PCFY-P63VKM-E**

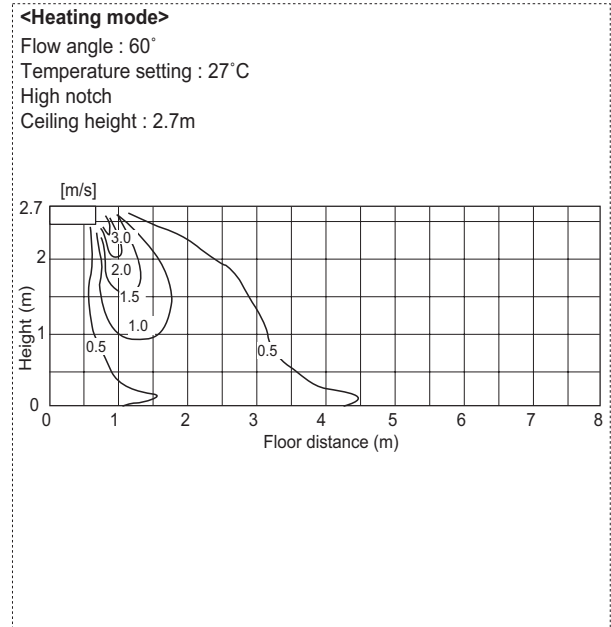
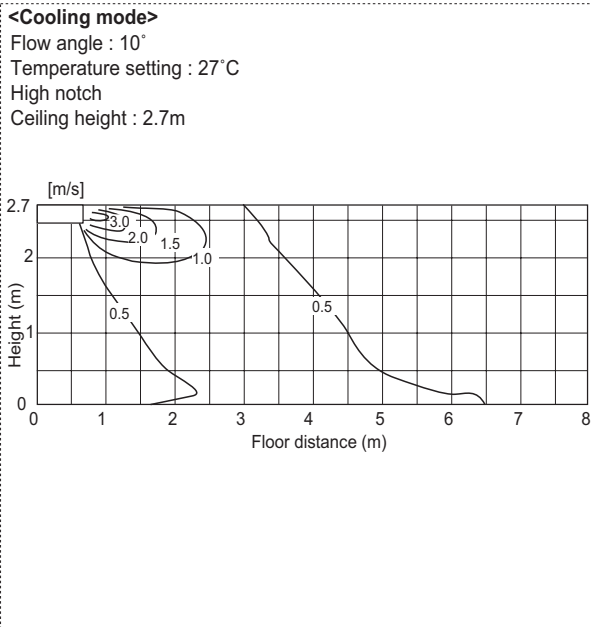

PCFY-P125VKM-E

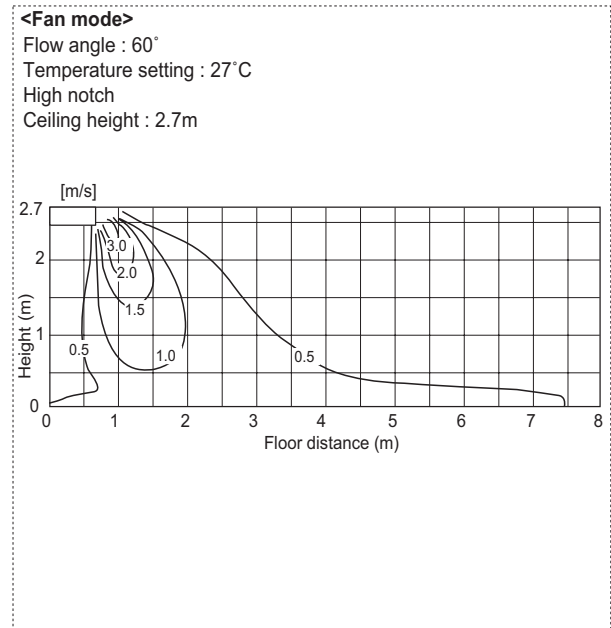
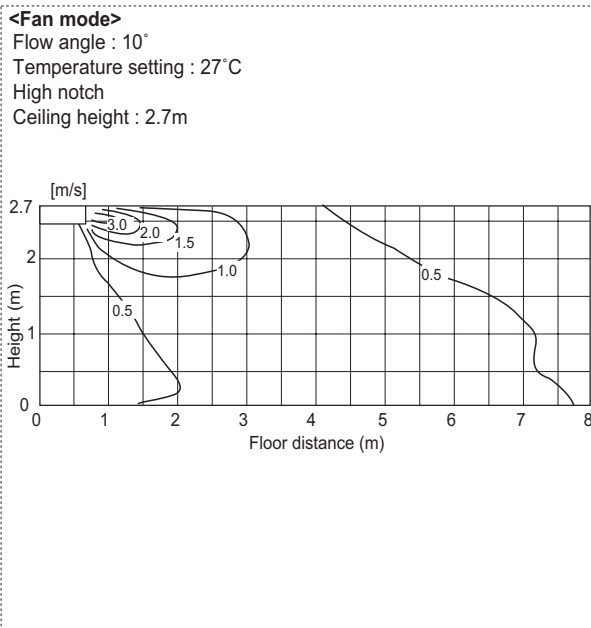

Note : These figures show typical airflow distributions in the conditions above. In the actual installation, they may differ from these figures under the influence of air temperature conditions, ceiling height, cooling/heating load, obstacles, etc.

PCFY

8-1. Optional parts line up for the Indoor unit





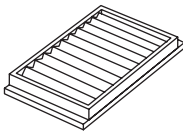

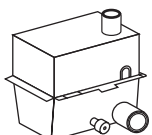
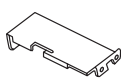

	High-efficiency filter	Wireless remote controller kit	Drain pump
PCFY-P40VKM-E	PAC-SH88KF-E	PAR-SL94B-E	PAC-SH83DM-E
PCFY-P63VKM-E	PAC-SH89KF-E	PAR-SL94B-E	PAC-SH84DM-E
PCFY-P100,125VKM-E	PAC-SH90KF-E	PAR-SL94B-E	PAC-SH84DM-E

8-2. High efficiency filter

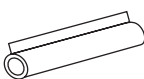
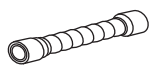
Material: PP honeycomb Grarimetric method: 70%			
m e t l	PAC-SH88KF-E	PAC-SH89KF-E	PAC-SH90KF-E
y t i t n a u	Q 2 (Small)	1 (Small), 2 (Large)	2 (Large)
Shape			

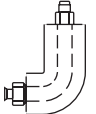
8-3. Drain pump

If drain water can not flow out the Indoor unit by gravity and gradient, a Drain-pump for draining is needed.
Drain pump PAC-SH-DM-E can pump water up to 600 mm high from the ceiling.

Item	① Drain lift up mechanism	② Attachment	③ Screws (4×10)	④ VP-20 pipe	⑤ Pipe cover
Quantity	1	1	6	1	1
Shape		 1 Drain lift up mechanism fixture	 For the installation of drain lift up mechanism 1		 For insulation of VP20 pipe4
Item	⑥ Flexible hose	⑦ Fastener	⑧ L-shaped pipe (gas pipe)	⑨ L-shaped pipe (liquid pipe)	⑩ Insulator A
Quantity	1	1	1	1	2
Shape					 6t×220×80 (For internal insulation) For the insulation of L-shaped pipes ⑧ and ⑨ and the refrigerant pipes.
Item	⑪ Insulator B				
Quantity	2				
Shape	 3t×250×120 (For external insulation) For the insulation of L-shaped pipes ⑧ and ⑨ and the refrigerant pipes.				

Detailed installation information should be referred to its Installation Manual (RG79V973H01).

8-4. Wireless remote controller kit

Wireless remote controller receiver is built-in type.

Item	① Wireless remote controller receiver	② Wireless remote controller	③ Remote control holder	④ "AAA" LR3 alkaline batterise	⑤ 4.1 x 16 wood screw
Quantity	1	1	1	2	2
Item	⑥ Cord rataining clips	⑦ Connection cord fixing seal (12x30 size)			
Quantity	2	1			

Detailed installation information should be referred to its Installation Manual (RG79V995H01).